

Pump/Motor Mount Dampening Ring

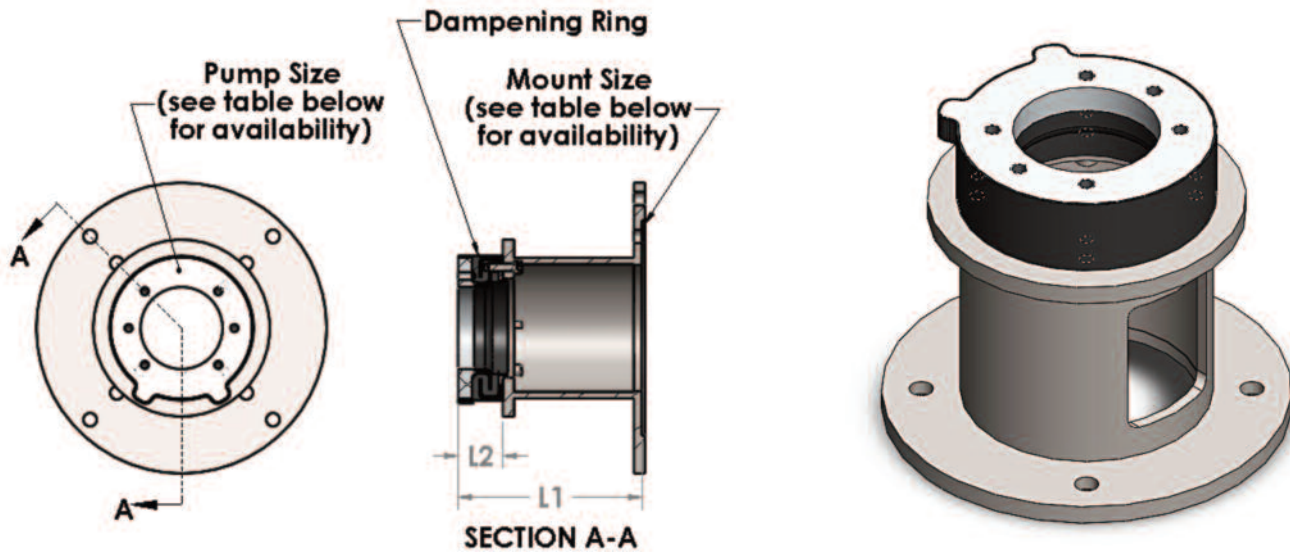

2

Magnaloy offers a line of Vibration/Noise Dampening Rings for use in conjunction with their Pump/Motor Mounts to provide reduced noise and vibration in these assemblies. These Pump/Motor Mount assemblies can be used in combination with Magnaloy's Motor Dampening Bars (page 157) to provide additional noise dampening capabilities. All Magnaloy Dampening Rings offer the features listed below and are available in both Welded Steel Pump/Motor Mounts and limited Aluminum Pump/Motor Mounts.

Selection Method: See page 18 (Horizontal application) or page 21 (Vertical application) for determining the length of the pump/motor mount required based upon the motor and pump being used. OR use Magnaloy's Product Configuration Program and select "Steel Mount" to obtain the length range for the pump/motor mount. From this length, subtract the length of the required Dampening Ring (dimension L2) shown in the table below. This will provide the length of the Pump/Motor Mount required for the application. Check this length against the available lengths of Aluminum Pump/Motor Mounts for the Motor size required. If no Aluminum Pump/Motor Mount is available in the length range specified, a Welded Steel Pump/Motor Mount will be necessary. Consult factory for assistance.

Features

- Design offers failsafe interlocking metal components with no direct contact and vulcanized for superior noise dampening.
- Design offers high load bearing capabilities for use with multiple pump arrangements.
- Excellent noise dampening characteristics.
- Excellent hydraulic fluid compatibility.

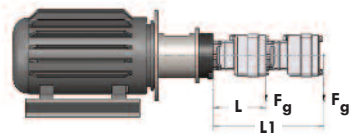

Horizontal Mounting

The Pump Weight (F_g), cannot exceed the Maximum Load (F_{max}) from table below.

NOTE: For Horizontal Mounting with C of G locations greater than L (shown in table below), use conversion formula.

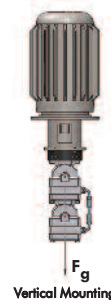

Vertical Mounting

Ring Size	D150	D190	D230	D260	D330
Characteristic					
Distance from face of Ring to C of G for load L	4 inch	4 inch	4 inch	8 inch	8 inch
Maximum Load F_{max}	2,900 lb	8,000 lb	13,300 lb	10,200 lb	18,200 lb

Conversion Formula

$$F_{g1} = F_{max} * L / L1$$

Note: if $L1 < L$, $F_{g1} = F_{max}$

Dampening Ring Availability

Dampening Ring Size	Motor Mount Avail Sizes	Motor End Data	Pump Flange Avail Sizes	Pump End Data	Dampening Ring Length (L2)	Mount Face-to-Face Length (L1)
D150	NEMA 056 NEMA 182	See Reference Section Page 172 for NEMA Motor Frame Dimensional data	SAE 4F17 thru SAE A 2/4 Bolt ISO 32 A2 thru ISO 80 A2/B4	See Reference Section Page 171 for Pump Flange Dimensional data	1.772	Determined by Motor and Pump Dimensional Data, consult factory
D190	NEMA 182 NEMA 284	See Reference Section Page 172 for NEMA Motor Frame Dimensional data	SAE 4F17 thru SAE B 2/4 Bolt ISO 32 A2 thru ISO 112 A2/B4	See Reference Section Page 171 for Pump Flange Dimensional data	1.772	Determined by Motor and Pump Dimensional Data, consult factory
D230	NEMA 284	See Reference Section Page 172 for NEMA Motor Frame Dimensional data	SAE B 2/4 Bolt thru SAE C 2/4 Bolt ISO 100 A2/B4 thru ISO 140 A2/B4	See Reference Section Page 171 for Pump Flange Dimensional data	2.283	Determined by Motor and Pump Dimensional Data, consult factory
D260	NEMA 324 NEMA 444	See Reference Section Page 172 for NEMA Motor Frame Dimensional data	SAE B 2/4 Bolt thru SAE C 2/4 Bolt ISO 100 A2/B4 thru ISO 16A0 A2/B4	See Reference Section Page 171 for Pump Flange Dimensional data	2.283	Determined by Motor and Pump Dimensional Data, consult factory
D330	NEMA 324 NEMA 444	See Reference Section Page 172 for NEMA Motor Frame Dimensional data	SAE C 2/4 Bolt thru SAE D 2/4 Bolt ISO 125 A2/B4 thru ISO 200 A2/B4	See Reference Section Page 171 for Pump Flange Dimensional data	3.268	Determined by Motor and Pump Dimensional Data, consult factory

2