

Quality.... Every Magnaloy reservoir is leak tested using a die penetrant, ensuring the integrity of each and every weld. In addition, every sharp edge and corner is deburred to help eliminate the risk of dangerous and costly injuries to assembly personnel. To insure a leakproof assembly, Magnaloy utilizes NPT Tapered Thread Fittings and Plugs for all Reservoir Drains.

Custom.... Whether a standard reservoir form our catalog, a hand sketch or DIN style, Magnaloy welcomes the opportunity to create a reservoir that will satisfy your application requirements. We specialize in pre-cut holes and/or special prepping of reservoirs reducing costly labor assembly time.

Value..... Our prices are competitive with all manufacturers of quality reservoirs. Magnaloy reservoirs arrive clean and ready to assemble. No costly labor required for cleanup. Other value added features include “one stop shopping” resulting in savings from fewer issued checks, purchase orders, correspondence and single source follow-up.

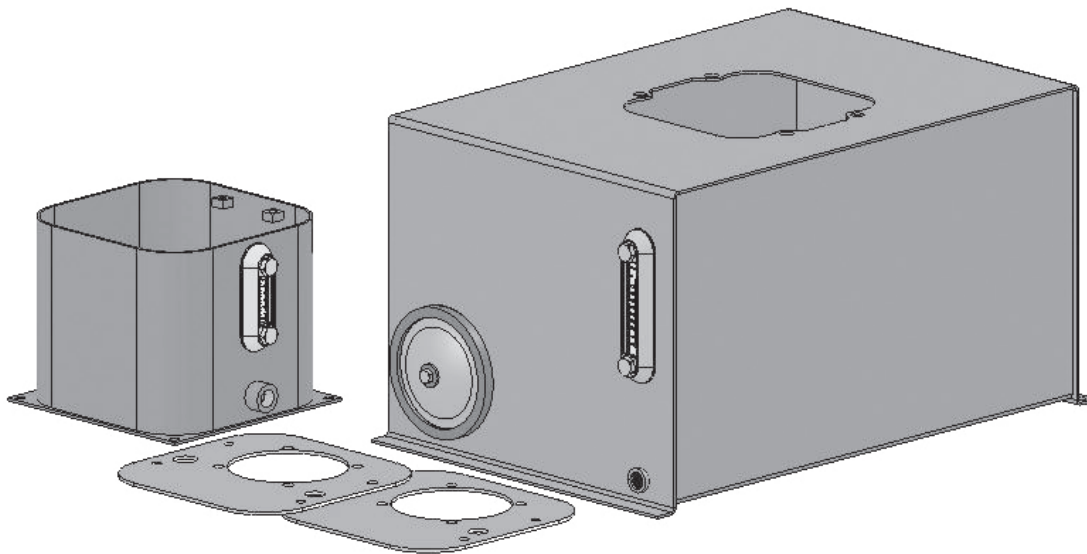

4

The Magnaloy tradition continues....

In the early planning stages of our reservoir line, a customer exclaimed, when learning of our new product, “if magnaloy is putting their name on it, that’s good enough for me.” Where other manufacturers dabble in expanding their product line, we take every new product very serious and ensure the magnaloy tradition of quality, value and support continues.

Other Magnaloy Reservoir Necessities....

Magnaloy offers a full line of Accessory Products for your reservoir. These include Filler Breather Caps, Adapters, Mounting Flanges, Screens, Suction Strainers, Spin-on and Tank Top Filters, Liquid Level Gauges and other products. See Magnaloy’s complete line of accessory items in our Accessory Products Catalog or visit us at www.magnaloy.com.