

General Information:

Standard Bar Manifold - includes specified NFPA valve pattern mounting on top of the manifold, A & B ports per specified thread type on the face of the manifold and pressure and tank ports per the specified thread type on each end of the manifold. Mounting provisions are included and defined on following manifold pages.

Options:

- Z - No Options** - indicates no options are provided (standard manifold)
- B - Bottom PR -TK ports** - additional pressure and tank ports per specified thread type located on the bottom of the manifold.
- C - Relief Valve Common Cavity** configurations added to the back surface of the manifold.
- G - Gauge Port** - addition of gauge port per specified thread type (see port size chart) to the face of the manifold to allow monitoring of the pressure "PR" passage.
- G4** - With Retro Design Manifolds Only - **#4 SAE Gauge Port** (with "S" thread code). Standard Gauge Port is #6 SAE (with "S" thread code) or 1/4 NPT (with "P" thread code).
- G6** - With Standard Design Manifolds - **#6 SAE Gauge Port** (with "S" thread code). Standard Gauge Port is #4 SAE (with "S" thread code) or 1/4 NPT (with "P" thread code).
- S - Relief Valve Sun Cavity** configuration added to the back surface of the manifold.
- H - Hard Metric Thread** - When British or Metric Thread type is specified, the valve and manifold mounting holes are also Metric Threaded.
- M - Soft Metric Thread** - indicates mixed metric threading. When NPT or SAE thread type is specified, valve mounting holes are metric threaded. No code "M" indicates the valve and manifold mounting holes are English threaded.
- I - Isolation Plug** - addition of an isolation plug(s) in the pressure or tank passage to provide signal isolation for valve operation. The location of the isolation plug is specified by indicating which station it is installed between. With the manifold positioned with the A & B ports facing forward, the valve mounting surfaces up and numbering from left to right, location A is between stations 1 & 2, location B is between stations 2 & 3, location C is between stations 3 & 4, etc. Isolation plugs can be installed in the pressure or tank passages or both. (See Note 1, next page and Reference Section, page 173)
- L - L Port** - addition of a drain port to the valve pattern on top of the manifold with a connecting port outlet on the back surface on the manifold. One port per station.
- O - Oversized A & B Ports** - (D05 High Flow and D05H-Alt.B only) - provides A & B ports machined oversized from the standard port size for additional flow capacity - see port size charts.
- P - Pilot Pressure** (D08 only) - addition of a pilot pressure signal port to the back surface of the manifold. One port per station.

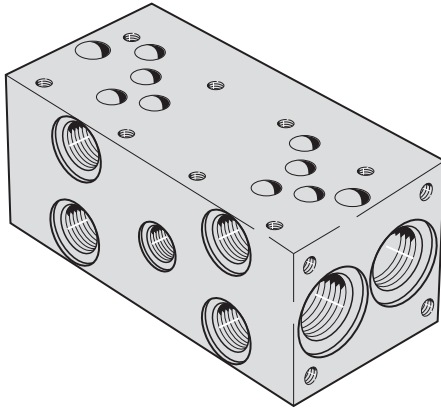

Standard Bar Manifolds

- 38 NFPA D03 Directional Valves in Parallel Circuits
- 40 NFPA D03 Directional Valves in Series Circuits
- 42 NFPA D03 Retro Design Directional Valves in Parallel Circuits
- 44 NFPA D03 High Flow Retro Design Directional Valves in Parallel Circuits
- 46 NFPA D05 Directional Valves in Parallel Circuits
- 48 NFPA D05 Directional Valves in Series Circuits
- 50 NFPA D05 High Flow Directional Valves in Parallel Circuits
- 52 NFPA D05E Alt.A Directional Valves in Parallel Circuits
- 54 NFPA D05H Alt.B Directional Valves in Parallel Circuits
- 56 NFPA D08 Directional Valves in Parallel Circuits
- 58 NFPA D08 High Flow Retro Design Directional Valves in Parallel Circuits
- 60 NFPA D08 Directional Valve in Series Circuits

Bar Manifold Hardware

- 173 Isolation Plugs for factory and field installation
- 174 Mounting Bracket Kits

MAGNALOY BAR MANIFOLD PART NUMBER BREAKDOWN

*** B M - A H P 0 3 P 2 - 0 2 - 1 / C**

- Product Code
 - BM-Inline Bar Manifold
 - BMR-Retro Inline Bar Manifold
 - Material Code
 - A - Aluminum
 - S - Ductile/Steel
 - Circuit Code
 - HP - High Flow Parallel Circuit
 - SP - Standard Flow Parallel Circuit
 - SS - Series Circuit
 - NFPA Pattern Code
 - 03 - D03
 - 05 - D05
 - 5E - D05E Alt. A
 - 5H - D05H Alt. B
 - 08 - D08
 - Thread Code
 - P - NPTF Pipe
 - S - SAE O'Ring
 - B - BSPP British Parallel
 - T - BSPT British Taper
 - M - Metric ISO 6149
- (See Port Size Chart for Standard Port Sizes)*

- Options
 - Z - No Option
 - B - Bottom PR-TK Ports
 - C - Relief Valve Cavity C-10-2, C-16-2
 - G - Gauge Port #4 SAE or 1/4" NPTF
 - G4 - Gauge Port #4 SAE
 - G6 - Gauge Port #6 SAE
 - L - L Port
 - O - Oversized A and B Ports
 - P - Pilot Pressures (Individual Per Station)
 - S - Relief Valve Cavity Sun T-10A, T-3A, T-16A
 - H - Hard Metric Threading ^{Note 2}
 - M - Soft Metric Threading ^{Note 3}
 - I - Isolation Plug ^{Note 1} - List as last option designated
- Note: For more than two combined options, Consult Factory.*

- Design Series
 - Number of Valve Stations
 - 01 - 1 stations
 - 02 - 2 stations
 - etc.
 - Valve Spacing Code
 - D03 2 = 2.00" (2.13" on D03 Retro Design)
 - 4 = 4.00"
 - D05 3 = 3.25"
 - 5 = 5.00"
 - D08 5 = 5.25"
 - 7 = 7.00"
- (For Special Spacing requirements, please consult factory.)*

* Not all codes and options are available in combinations, see following Manifold Pages for specific Magnaloy standard configurations and options.

Notes:

| <p>1 - Isolation Plug Location is specified by using the following codes after the "I" option designation:</p> <table border="0" style="width: 100%;"> <tr> <th style="text-align: left;">Port</th> <th style="text-align: left;">Location*</th> </tr> <tr> <td>P - Pressure Port</td> <td>A - Between Stations 1 & 2</td> </tr> <tr> <td>T - Tank Port</td> <td>B - Between Stations 2 & 3</td> </tr> <tr> <td></td> <td>C - Between Stations 3 & 4</td> </tr> <tr> <td></td> <td>D - Between Stations 4 & 5 (etc.)</td> </tr> </table> | Port | Location* | P - Pressure Port | A - Between Stations 1 & 2 | T - Tank Port | B - Between Stations 2 & 3 | | C - Between Stations 3 & 4 | | D - Between Stations 4 & 5 (etc.) | <p>Examples:</p> <ul style="list-style-type: none"> Option Code for Pressure Isolation between stations 3 & 4 = IPC Option Code for Tank Isolation between stations 1 & 2 = ITA Option Code for Pressure Isolation between stations 1 & 2 and Tank Isolation between stations 2 & 3 = IPATB <p>*Location is determined with A & B ports facing forward, valves up and numbering from left to right</p> |
|--|-----------------------------------|-----------|-------------------|----------------------------|---------------|----------------------------|--|----------------------------|--|-----------------------------------|--|
| Port | Location* | | | | | | | | | | |
| P - Pressure Port | A - Between Stations 1 & 2 | | | | | | | | | | |
| T - Tank Port | B - Between Stations 2 & 3 | | | | | | | | | | |
| | C - Between Stations 3 & 4 | | | | | | | | | | |
| | D - Between Stations 4 & 5 (etc.) | | | | | | | | | | |

2 - Hard Metric Threading - Used with British and Metric Thread Type to indicate Valve Mounting is also Metric Threaded

3 - Soft Metric Threading - Used with NPT or SAE Thread Type to indicate Valve Mounting is Metric Threaded (No Code Designation Indicates Valve Mounting is English Threaded)