

Flow from P to A/B Port

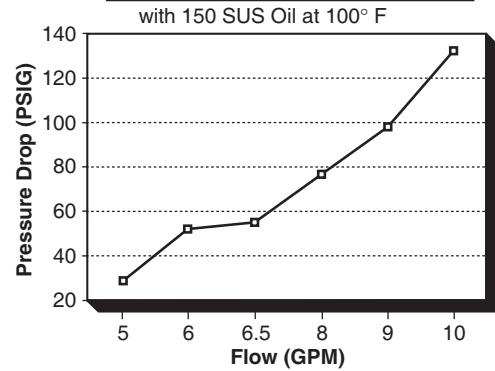

Dimensions

No of Stations	L	E	F
1	2.75" *	2.00"	-
2	4.75"	4.00"	-
3	6.75"	6.00"	-
4	8.75"	8.00"	-
5	10.75"	10.00"	-
6	12.75"	12.00"	-
7	14.75"	14.00"	8.00"
8	16.75"	16.00"	8.00"
9	18.75"	18.00"	8.00"
10	20.75"	20.00"	10.00"
11	22.75"	22.00"	8.00" & 16.00"
12	24.75"	24.00"	8.00" & 16.00"
13	26.75"	26.00"	8.00" & 16.00"
14	28.75"	28.00"	10.00" & 20.00"

Shaded area - Please consult factory for delivery.

* For Single Station with B, C, S, G, or G6 Options, "L" = 3.75"

Features & Advantages

- * The efficient design provides excellent flow rates with minimal pressure drop.
- * Standard end mount and through holes make mounting easy and flexible. Also, (when requested) mounting bracket kit BK-A03 (no charge) or flange mount kit FK-03 (additional cost) is available with the manifold as alternative mounting styles.
- * Available with SAE, NPTF, BSPP, BSPT or Metric Threads to cover a wide range of applications.
- * Options include relief valve cavity, bottom PR & TK ports, and gauge port to fit specific circuit requirements.

3

MAGNALOY D03 PARALLEL BAR MANIFOLD PART NUMBER BREAKDOWN

B M - A S P 0 3 P 2 - 0 2 - 1 / C

Product Code _____
BM-Inline Bar Manifold

Material Code _____
A - Aluminum
S - Ductile/Steel

Circuit Code _____
SP - Standard Flow Parallel Circuit

NFPA Pattern Code _____
03 - D03

Thread Code _____
P - NPTF Pipe
S - SAE O'Ring
B - BSPP British Parallel
T - BSPT British Taper
M - Metric - ISO 6149
(See Port Size Chart for Standard Port Sizes)

Options

- Z - No Option
- B - Bottom PR-TK Ports
- C - Relief Valve Cavity C-10-2
- G - Gauge Port #4 SAE or 1/4" NPTF
- G6 - Gauge Port #6 SAE
- S - Relief Valve Cavity Sun T-10A
- H - Hard Metric Threading *(See Note 2, page 34)*
- M - Soft Metric Threading *(See Note 3, page 34)*
- I - Isolation Plug¹ - List as last option designated *(See Note 1, page 34)*

Note: For more than two combined options, please consult factory.

Design Series

Number of Valve Stations

- 01 - 1 stations
- 02 - 2 stations
- etc.

Valve Spacing Code

- 2 - 2.00"
- 4 - 4.00"

(For Special Spacing requirements, please consult factory.)

Inline Bar Manifold

D03 Standard Flow Bar Manifold - Parallel

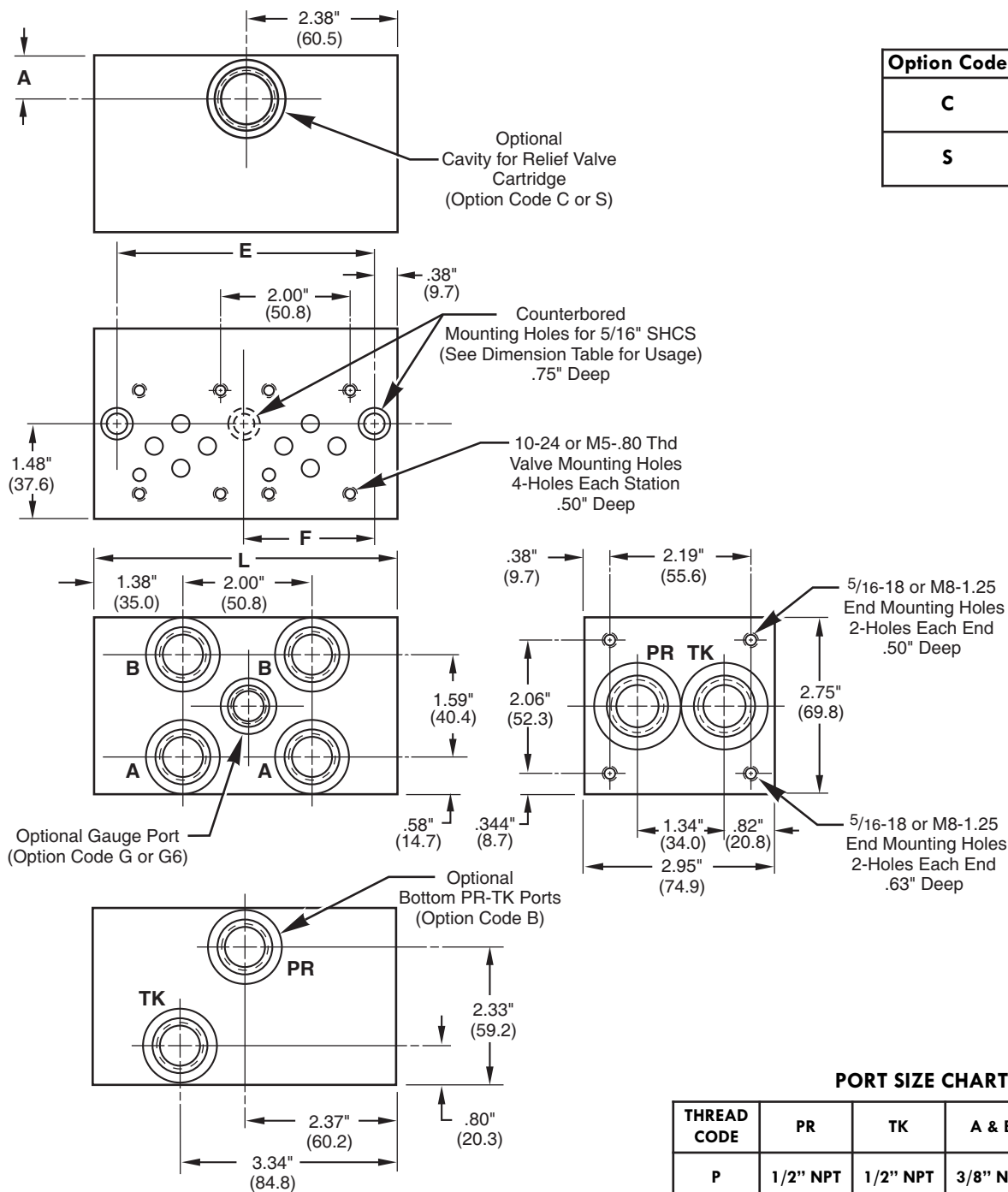

Option Code	A
C	.69" (17.5)
S	.81" (20.6)

NOTE: For End Mounting Bracket Kit (BK-A03) and Mounting Flange Kit (FK-A03) dimensions, see Reference Section, page 174.

PORT SIZE CHART

THREAD CODE	PR	TK	A & B	OPTIONAL GAUGE PORTS
P	1/2" NPT	1/2" NPT	3/8" NPT	1/4" NPT
S	#10 SAE	#10 SAE	#8 SAE	#4 SAE G6 - #6 SAE
B	1/2" BSPP	1/2" BSPP	3/8" BSPP	-
T	1/2" BSPT	1/2" BSPT	3/8" BSPT	-
M	M22	M22	M18	-