

For Continuous reading of Fluid Level and Temperature

Standard Line - Liquid Column Series

Features:

- UV Resistant Transparent Dupont Grilamid Case
- All-Around Visibility of the Fluid Level
- Buna-N O-ring Seals
- Zinc Plated Bolts
- Available with Optional Cast Aluminum Cover to Provide additional breakage protection
- Includes Thermometer with Blue Fluid for easy readings
- 212° F Maximum Temperature Rating
- For use with Petroleum and Water Base Hydraulic Fluids, consult factory for other fluids

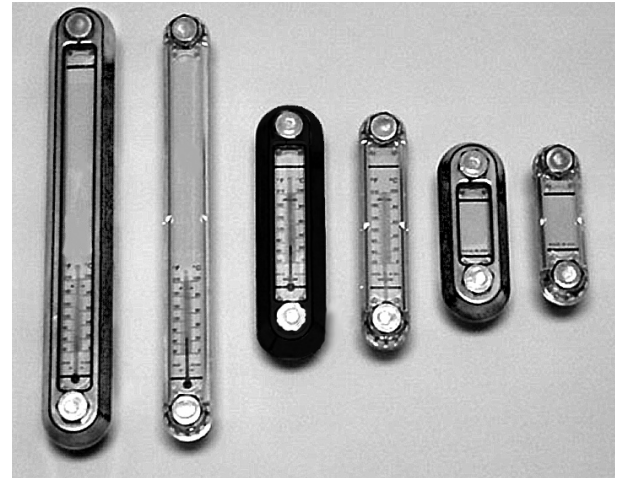

5

W/Out Cover

With Cover

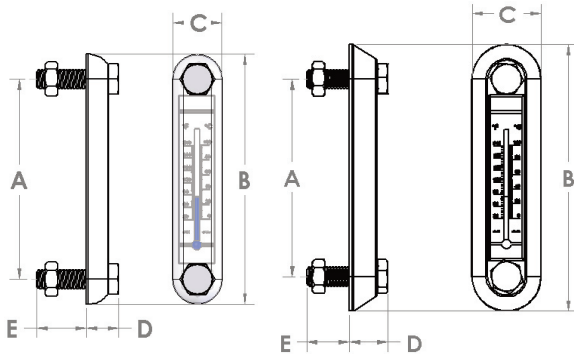

Part Number	Description	A	B	C	D	E
SLLG-03T	Std 3" w/temp	3.00"	4.22"	1.22"	0.81"	1.16"
SLLG-03T-C	Std 3" w/temp & Cover	3.00"	4.75"	1.75"	0.93"	0.82"
SLLG-05T	Std 5" w/temp	5.00"	6.22"	1.22"	0.81"	1.16"
SLLG-05T-C	Std 5" w/temp & Cover	5.00"	6.75"	1.75"	0.93"	0.82"
SLLG-10T	Std 10" w/temp	10.00"	11.22"	1.22"	0.81"	1.16"
SLLG-10T-C	Std 10" w/temp & Cover	10.00"	11.75"	1.75"	0.93"	0.82"

Premium Line - Liquid Column Series

Features:

- Borosilicate sight glass compatible with all hydraulic fluids and will not discolor
- 20 PSI maximum working pressure at 250° F
- May be front mounted by threaded tank holes or rear mounted with provided nuts
- Mounting bolts provide 1/16" alignment adjustment to facilitate installation
- Low profile body offers wide sight opening for visibility
- Machined from solid Aluminum bar stock
- Includes internal thermometer - external thermometer available - consult factory



Premium LLG Line

Warning: Not recommended for use with acidic fluids, caustic fluids, volatile fluids, water and steam

Liquid Level Gauges



Premium Line (continued)

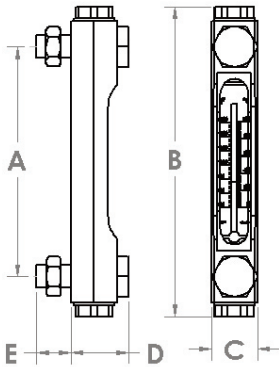

Part Number	Description	A	B	C	D	E
PLLG-03T	Premium 3" w/temp	3.00"	4.63"	1.00"	1.23"	0.75"
PLLG-05T	Premium 5" w/temp	5.00"	6.63"	1.00"	1.23"	0.75"
PLLG-10T	Premium 10" w/temp	10.00"	11.63"	1.00"	1.23"	0.75"

How to Order:

SLLG-03T-C-2

Code	Series
SLLG	Standard Liquid Level Gauge
PLLG	Premium Liquid Level Gauge

Code	Bolt Center Distance
03	3"
05	5"
10	10"

Code	Mounting Bolt Option
Blank	1/2-13 UNC (1)
2	M12 x 1.75 Metric (2)

Code	Cover (Guard) Option
Blank	No Cover
C	with Cover (3)

Notes:

- 1 - 1/2-20 UNF with Premium Line
- 2 - Not Available with Premium Line
- 3 - Premium Line design incorporates integral gauge guard

Sight Glass Series

Features:

- Clear Nylon Fluid Level sight glass with Steel Collar for weld attachment to reservoir
- 400 PSI maximum working pressure
- Temperature Range: -65° F to 150° F for pressure applications
- For use with Petroleum Base and Water Base Hydraulic Fluids

Order Part Number: SLSG-100

